

S6061SC-10/15 series spring return damper actuator

Technical datasheet:

Summary:

The damper actuator is specially designed for small and middle air damper and terminal control unit of air volume system. By the change of input signal, the actuator can be controlled at any point. It can supply a feedback signal of 0-10V, after cut the power, the actuator can return by the spring.



Features:

- Can be controlled by 2/3 point or 0...10V
- Screw terminal connection
- Shaft size: Max.φ19mm.
- Selectable direction of rotation
- Two Optional Auxiliary Switches
- Using fixed, compact and anti-impact steel shell.
- IP 54 standard.

Item	S6061SC-10D/24V	S6061SC-10D/230V	S6061SC-10A/24V	S6061SC-15D/24V	S6061SC-15D/230V	S6061SC-15A/24V
Torque	10Nm			15Nm		
Damper area	2m ²			3m ²		
Power supply	24VAC/DC, 110V-250VAC 50/60Hz					
Operating Power Consumption	5W			6W		
At end stops Power Consumption	2.5W			2.5W		
Wire size	10VA		7VA	10VA		7VA
Connection cable	D type power: 1m cable 2*0.75m ²			A type power: 1m cable 4*0.5		
	Auxiliary switch (F) : 1m cable 6*0.5 m ²					
Control signal	On/off		0~10V	On/off		0~10V
Running time	Motor≤100S; spring return≤30S			Motor≤130S; Spring return≤30S		
Rotation angle	0~90°(Max 93°)					
Limited angle	5~85° (Per step5°)					
Indicate	Mechanical indicator					
Weight	2.4Kg					
Life cycle	70000					
Noise	50dB(A) and 62dB(A)					
Electric level	III	II	III	III	II	III
IP protection	IP54					
Temperature	-20~+50°C					
Humidity	5~95%RH					
Certificate	CE UL EAC					

Wiring diagram:

Modulating damper actuator can be controlled by 0-10V

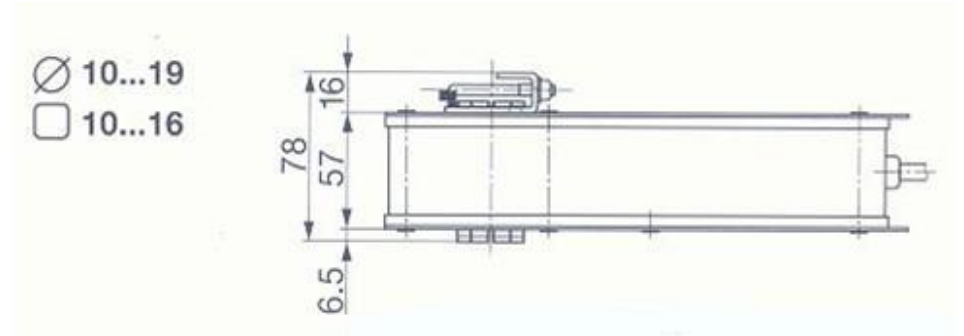
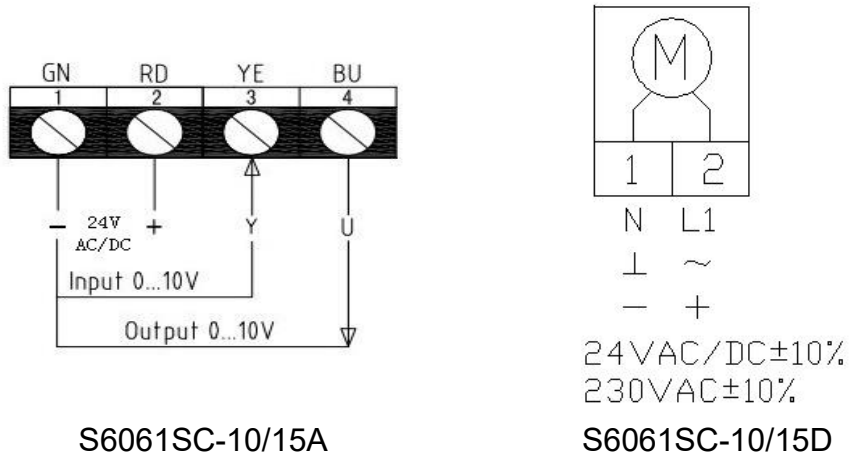

Auxiliary switch:

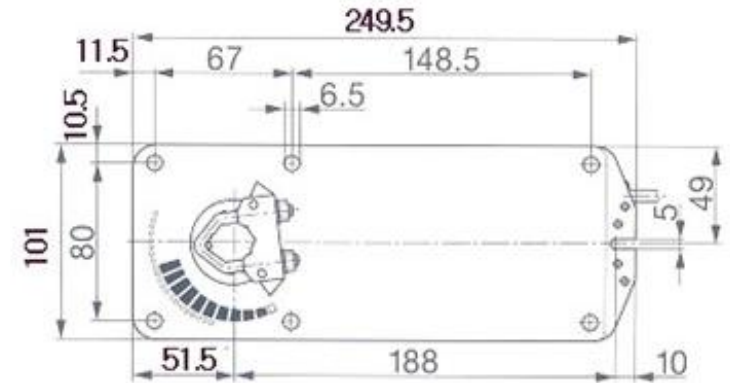
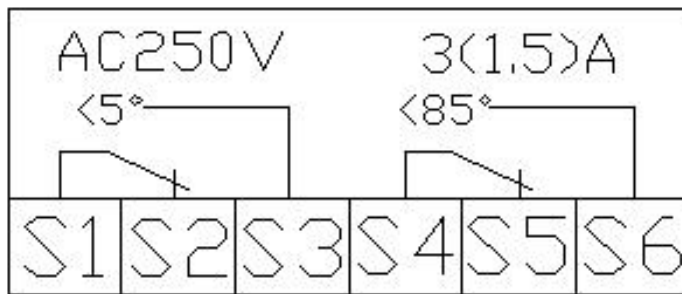

1. The installation must be carried out by personnel who have received relevant training or relevant work experience. During the installation process, be careful not to operate with electricity, and install the actuator according to the regulations.



2. The device contains electrical and electronic accessories, so it is forbidden to dispose of it as ordinary garbage after the product is scrapped, and the treatment method should comply with the regulations and requirements of the local government.