

02 ExS6061SF Series Explosion-Proof Spring Return Fire and Smoke Damper Actuators

This series of actuators is designed for damper control in environments/workplaces with explosive hazardous gases, steam or combustible dust in HVAC, petroleum, petrochemical, metallurgy, ships, power plants, nuclear power plants, pharmaceutical plants, etc. It has obtained China Compulsory Certification (CCC), EU ATEX, IECEx certification, and Russian EAC certification.

► Features

Torque

05Nm、10Nm、
15Nm

Nominal Voltage

AC/DC 24V
AC 220V

Control Method

On/Off

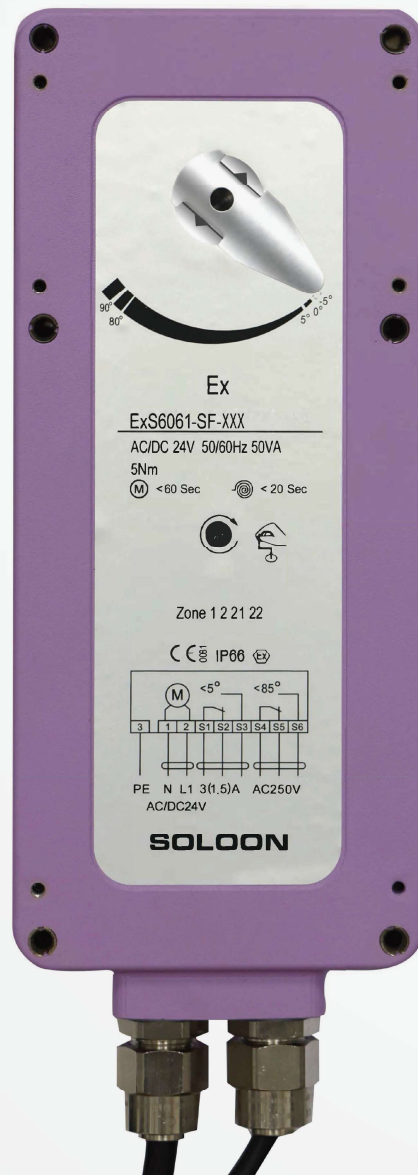

► **Order Code**

ExS6061 **SF** - **XX** **D** **F** / **X**

- Voltage (AC/DC 24V or AC 220V)
- Auxiliary Switch F: 2 SPDT
- Control Type: D (On/Off)
- Torque: 5Nm, 10Nm, 15Nm
- SF: Spring Return Fire Damper Actuator

► **ExS6061SF Technical Specifications**

Items	ExS6061SF-05DF/24V	ExS6061SF-05DF/220V	ExS6061SF-10DF/24V	ExS6061SF-10DF/220V	ExS6061SF-15DF/24V	ExS6061SF-15DF/220V
Torque (Nm)	5Nm		10Nm		15Nm	
Damper Size (m ²)	1m ²		2m ²		3m ²	
Running Time (sec)	Motor ≤150s; Spring Return ≤30s					
Nominal Voltage (V)	AC 220V; AC/DC 24V50/60Hz; i ≤0.2A					
Supply Voltage Range (V)	AC/DC 19.2-28.8V; AC 85-265V					
Power Consumption (on)	7W		10W		12W	
Power Consumption (off)	3W					
Reactive Power (VA)	10					
Cables	Power: 1m 3*0.75mm ² ; Auxiliary Switch (F): 1m 6*0.5mm ²					
Weight (Kg)	5Kg					
Control Signal	On/Off					
Position Indication	Max 93°					
Rotation Angle	L/R Switch					
Auxiliary Switch	2 Auxiliary Switches					
Life Cycle	≥10000					
Sound Power Level	50dB and 62dB					
Electrical Protection Class	II /III					
Ingress Protection	IP66					
Ambient Temp/Humidity	-20~+60°C		5~95%RH			
Storage Temperature	-30~+70°C					
Shaft Diameter	10*10/12*12mm					
Ex Mark	Ex db II B T6 Gb; Ex tb IIIC T85°C Db					
Compliance	CCC, ATEX, IECEx, EAC certificates					

ExS6061SF/NS Series Explosion-Proof Fire and Smoke Damper Actuators

► ExS6061SF/NS Wiring Diagrams

ExS6061SF

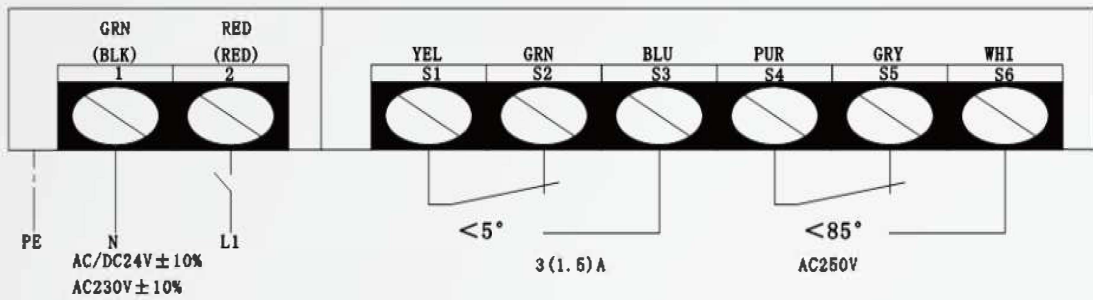

ExS6061NS

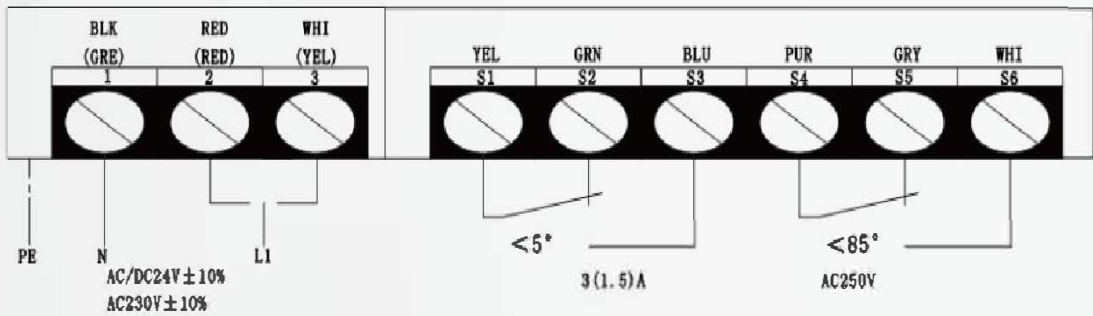

► ExS6061SF/NS Dimensions unit (mm)

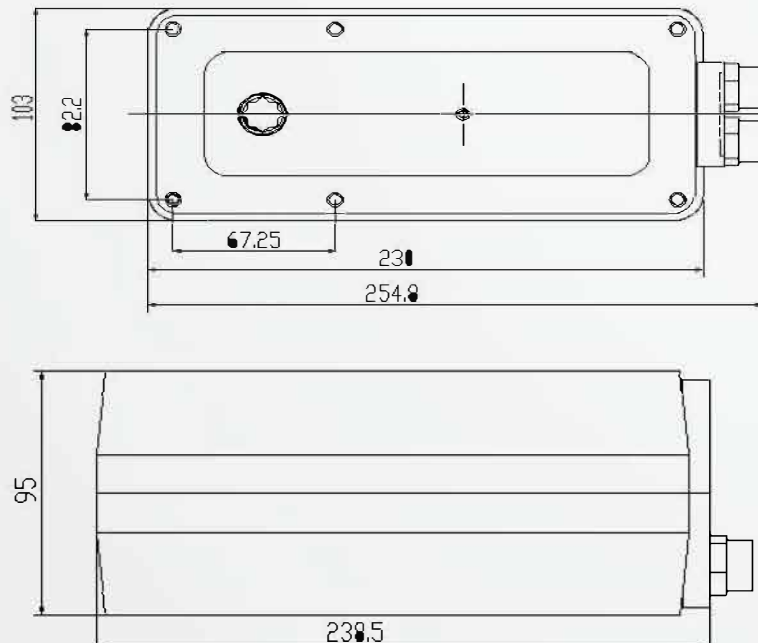

► Complies With The Following Standards

- ◆ GB/T 3836.1-2021 Explosive atmospheres Part 1: General requirements
- ◆ GB/T 3836.2-2021 Explosive atmospheres Part 2: Equipment protected by flameproof enclosures "d"
- ◆ GB/T 3836.31-2021 Explosive atmospheres Part 31: Equipment dust ignition protection by enclosure "t"

► Use and Maintenance

- ◆ The thread size of the cable connector and the external enclosure is M16×1.5, the cable diameter is $\Phi 6-\Phi 8$, and the cable connector must have a corresponding explosion-proof certificate.
- ◆ The tightening torque of the internal grounding terminal is 2Nm; the tightening torque of the flameproof surface is 3.2Nm; the external grounding bolt is M4X6, compressing the 4mm² conductor.
- ◆ The entrance should be equipped with a cable gland with explosion-proof certification, and a compatible protection mode for the specified purpose.
- ◆ In addition to using the installation manual, the operator should comply with the requirements of GB 3836-13 during assembly, operation and maintenance.
- ◆ Maintenance and overhaul should comply with the requirements of GB 3836-16.
- ◆ The product enclosure should be cleaned with a damp cloth.
- ◆ Users are prohibited from repairing and modifying the flameproof content.

► Warnings

- ◆ It is strictly forbidden to disassemble privately, and it is strictly forbidden to open the cover when power is on; please do not open it in dangerous places; wipe it with a damp cloth when opening it.
- ◆ After power off, delay 10 minutes before turning on.
- ◆ Potential electrostatic hazards.
- ◆ Use fasteners with a yield stress of $\geq 450\text{MPa}$.
- ◆ The fireproof joints cannot be repaired or modified by the user.
- ◆ It must be installed by personnel who have received relevant training or relevant work experience. During the installation process, be careful not to operate with power on, and install the actuator according to the regulations.
- ◆ There are electrical and electronic accessories in the device, so it is forbidden to dispose of it as ordinary garbage after the product is scrapped. The disposal method should comply with the regulations and requirements of the local government.

► Special Conditions of Use

- ◆ Fireproof joints cannot be repaired or modified by the user.
- ◆ Imported parts should be equipped with Ex-certified cable sheaths, and its protection mode should be compatible with the intended use.
- ◆ During assembly, operation and maintenance, the operator should comply with the requirements of GB 3836-13, and should indicate it next to the instruction manual.
- ◆ Repairs and overhauls should comply with GB 3836-16.

► Product Functions and Application Instructions

- ◆ Explosion-proof electrical appliances refer to a class of electrical equipment used in places where explosive gases and vapors exist.
- ◆ Coal, petroleum, chemical, textile and other industries in the national economy occupies a very important position, these industries in the production process will produce explosive gas. Steam or explosive dust, such places are called explosive dangerous places.
- ◆ The explosion-proof type air valve actuators produced by our company are Class II (not mine) explosion-proof electrical equipment.